

MANUAL FOR PMS-50 MOTHER BOARD

CONNECTION DIAGRAMS

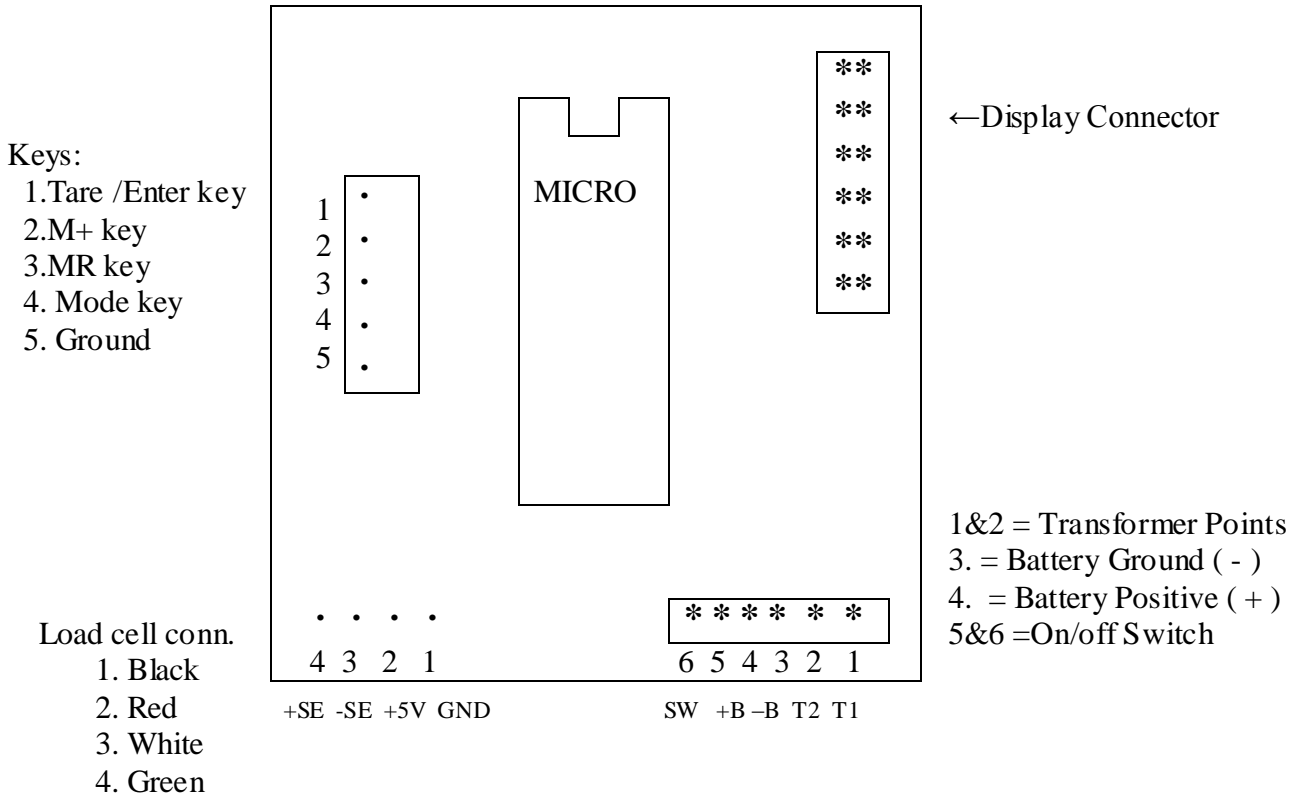

OPERATIONS / SETTINGS

- 1). **Hold MR Key Power on**
UNLOC= Enter Master password (2011)
PASWAD = Change Parameter setting password
FNAME = Enter Farm name (6+6=12 char. Lenth of name)

- 2). **Hold M+ key power = (Enter parameter setting password)**
Fn 1 = Press Mode Key Direct jump to **Fn2**
 Or Press Tare Key for open Parameters
MF= mode function :1= counting , 3= litre/ % (Optional)
DSS= display mode:0 = weigh mode,1= save mode.
A-0 = auto-zero tracking counts (0- 9)
DU-0 = dummy zero:0= normal weighing without dummy zero
 1= with dummy zero
 2= dual accuracy (0.5/1) or (5/10)
CS = open No. of Capacity Selection 1 = Only One Cap.
 2= Two Cap.
 3= Three Cap.
Fn 2 = Press Mode Key Direct jump to **Fn3**
 Or Press Tare Key for open Parameters

CAP-1= first capacity (first scale range for triple capacity) (Enter)
(if not use inter 00000 value)
DP1 = decimal point (DP) of cap1
FD1= accuracy class (FIRST DIGIT) of cap1
CAP-2= second scale capacity (enter)
(if not use inter 00000 value)
DP2 = decimal point (DP) of cap2
FD2 = accuracy class (FIRST DIGIT) of cap2
CAP-3= scale capacity (enter)
DP3 = decimal point (DP) of cap3
FD3 = accuracy class (FIRST DIGIT) of cap3

Fn3

Litd = litre density / % value , fifth digit 0=litre mode
Fifth digit 1= % mode

- 4). Hold **MODE key** power on = see machine internal count
On No load machine count must be 3000 to 8000 count
Usable machine count are upto 100000

5). **CALIBRATION:**

Make sure that the Machine is in weighing mode
Keep Weight on the Pan/ platform (near 30% of m/c capacity.)
Press MR key and hold then press **MODE key**
Display Show **PASSWAD** (Enter)
If display show **READML** (Then check your weight)
Display show **00000** (feed above weight by **M+& MR** Keys)
Press **ENTER KEY** to complete calibration.

6). **COUNTING FUNCTION :**

Make sure that machine is in weighing mode
Keep some pieces on the pan/ platform
Display show you the weight
Press MR Key & M+ Key display show **COUNT**
Then press **TARE/ENTER key**
Display show **P. 00000**
Enter the number of pieces which kept on the pan (press Enter key)
Now machine working in counting mode.
For weight mode , press again **MODE key** .