

MANUAL FOR PMS-68 MOTHER BOARD
CONNECTION DIAGRAMS

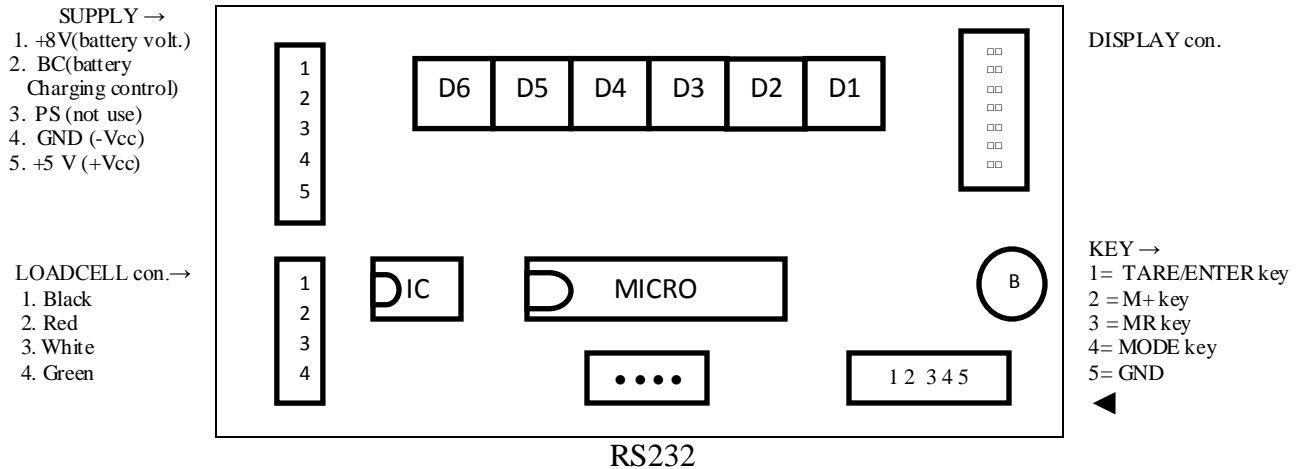

Main Features:

- 1). Latest Technologies of weighing Scale Micro and ADC.
- 2). **Microcontroller** Based Battery Charging (Battery Life More).
- 3). PTH 300000 (Three Laces) ADC counts for Utilization.
- 4). Totally Moisture Proof Designing.
- 5). Micro and ADC protects from STATICS charges.
- 6). 100 Hours Battery BACK-UP.
- 7). Upgraded to pricing counting/piece counting scale.
- 8). Buzzer Beep Indication for low battery.
- 9). Battery Voltage monitoring by Microcontroller.

1. OPERATIONS / SETTINGS

Hold MR Key Power on

UNLOC= Enter Master password (2013)

PASWAD = Change Parameter setting password

FNAME = Enter Farm name (6+6=12 char. Length of name)

2). Hold M+ key power = (Enter parameter setting password)

MF= mode function :1= counting , 3= liter / % (Optional)

DSS= display mode:0 = weigh mode,1= save mode.

A-0 = auto-zero tracking counts (0- 9)

DU-0 = dummy zero: 0= without dummy zero

1= with dummy zero

2= dual accuracy (0.5/1) or (5/10)

CS = Capacity Selection 1 = Only One Cap.

2= Two Cap.

3= Three Cap.

CAP-1= first capacity (first scale range for triple capacity) (Enter)

(If not use inter 00000 value)

DP1 = decimal point (DP) of cap1

FD1= accuracy class (FIRST DIGIT) of cap1

CAP-2= second scale capacity (enter)

(If not use inter 00000 value)

DP2 = decimal point (DP) of cap2

FD2 = accuracy class (FIRST DIGIT) of cap2

CAP-3= scale capacity (enter)

DP3 = decimal point (DP) of cap3

FD3 = accuracy class (FIRST DIGIT) of cap3

Litd = Feed liter density

3). Hold **MODE key** power on = see machine internal count

On No-load machine count must be 3000 to 12000 count

Usable machine counts are up to 300000

CALIBRATION:

Make sure that the Machine is in weighing mode

Keep Weight on the Pan/ platform (near 30% of m/c capacity.)

Press MR Key and hold then press **MODE key**

Display Show **PASSWAD** (Enter)

If display shows **READML** (Then check your weight)

Display show **00000** (feed above weight by **M+ & MR** Keys)

Press **ENTER KEY** to complete calibration.

COUNTING FUNCTION:

Make sure that machine is in weighing mode.

Keep some pieces on the pan/ platform.

Display shows you the weight.

Press MR Key & M+ Key display show **COUNT**

Then press **TARE/ENTER key**

Display show **P. 00000**

Enter the number of pieces which kept on the pan (press Enter key)

Now machine working in counting mode.

For weight mode, press again **MODE key**.