

MANUAL FOR PMS - 45 MOTHERBOARD SETTING
(Jewelry card)

PMS - 45

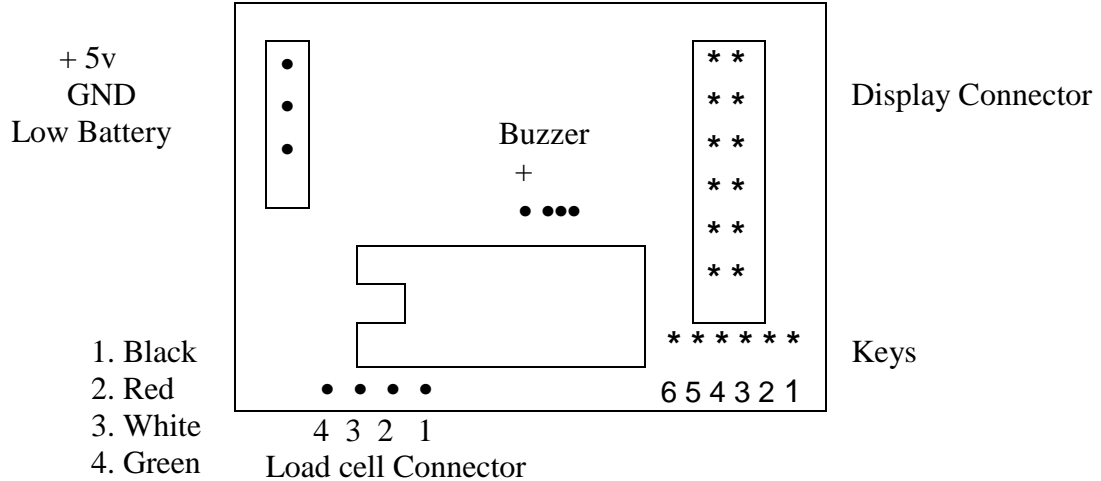

OPERATIONS / SETTINGS

• **STEP1**

- Hold **MR Key** power on
- UNLOC** = Enter Master password (2011)
- CHPASS** = Change machine password
- FNAME** = Enter Farm name

• **STEP2**

Hold **M+ key** power = (Enter machine password)

MF= mode function selection: For normal cards

- | | |
|-------------|-----------------------|
| 1= counting | 4. = Carat & counting |
| 2= Carat | 5. = Carat & Tolla |
| 3= Tolla | 6. = Counting & Tolla |

DSS= display saving mode 0 = weigh mode

1= last single zero, or only last DP

A-0 = auto-zero tracking counts (0- 5)

DU-0 = dummy zero 0= normal weighing without dummy zero

1= with dummy zero

2= dual accuracy (0.5/1 /mg) or (5/10 /mg)

CS = No. of Capacity Selection 1 = Only One Cap.

2 = Two Cap.

3 = Three Cap.

CAP-1= first capacity (first scale range for triple capacity) (Enter)

(If not use inter 00000 values)

PMS TECHNOLOGIES , JAIPUR

DP1 = decimal point (DP) of cap1

FD1= accuracy class (FIRST DIGIT) of cap1

CAP-2= second scale capacity (enter)

(If not use inter 00000 value)

DP2 = decimal point (DP) of cap2

FD2 = accuracy class (FIRST DIGIT) of cap2

CAP-3= scale capacity (enter)

DP3 = decimal point (DP) of cap3

FD3 = accuracy class (FIRST DIGIT) of cap3

CALIBRATION

Make sure that the Machine is in weighing mode

Keep Weight on the Pan/ platform (near 30% of m/c Capt.)

Press MR Key and hold then press MODE key

Display show PASSWD (Enter)

If display shows READML (Then check your load)

Display show 00000 (feed above weight by M+& MR Keys)

Press ENTER to complete calibration

Now check machine's complete dynamic range and feed

Value of linearity as required.

COUNTING

Make sure that machine is in weighing mode

Keep some pieces on the pan/ platform

Display show you the weight

Press MR Key & M+ Key display show **COUNT**

Then press **TARE/ENTER** key

Display show **P. 00000**

Enter the number of pieces which kept on the pan (press Enter key)

Now machine working in counting mode.

For weight mode, press again **MODE** key.